

DIO IMPLANT

DISCOVER THE EXTENDED
16X10 FOV

Ray



RAYSCAN α +

By DIO IMPLANT

FACE-DRIVEN SOLUTION

Capture the full spectrum of facial and dental anatomy and achieve personalized and aesthetically pleasing treatment outcomes with the advanced technology of RAYSCAN α+. This technology ensures comprehensive imaging of dental and facial bones while minimizing radiation exposure. Our 3D face and intraoral scanners enable patient-specific treatment planning, serving as an indispensable and transformative tool that enhances and inspires lives

3D Face
Scanner

• CBCT •

Intraoral
Scanner

EMPOWERING DOCTOR

RAYSCAN $\alpha+$

RAYSCAN $\alpha+$ provides a comprehensive clinical perspective with its expanded Field of View (FOV) of 16x10, ensuring confident diagnoses and treatment planning.



Multi & Free FOV

FOV 16×10 max.
Free FOV Adjustments

Implantology, Periodontics, Endodontics
Orthodontics, Dual TMJ analysis
Sinus & airway analysis

High Resolution

$70 \mu\text{m}$ $160 \mu\text{m}$ $200 \mu\text{m}$
FOV 4x5 FOV 10x10 FOV 16x10

Accurate results instill confidence
in your diagnosis

Rapid Reconstruction Time

8 sec
HD Scan

The ability to review CT images quickly can
significantly reduce the time patients spend
waiting in the chair

Remote Control

Improved Patient Positioning &
Operator Ergonomics

Convenient and easy scanning

Expand your vision

RAYSCAN α+ can effectively capture all essential anatomical regions in various diagnostic scenarios with its expanded Field of View (FOV) of 16x10.



16 diameter

10 height

16 diameter

With a diameter of up to 16cm, offers an expanded field of view, allowing for comprehensive examination of full dentition, third molars, dual TMJ, airway, and cervical spine.

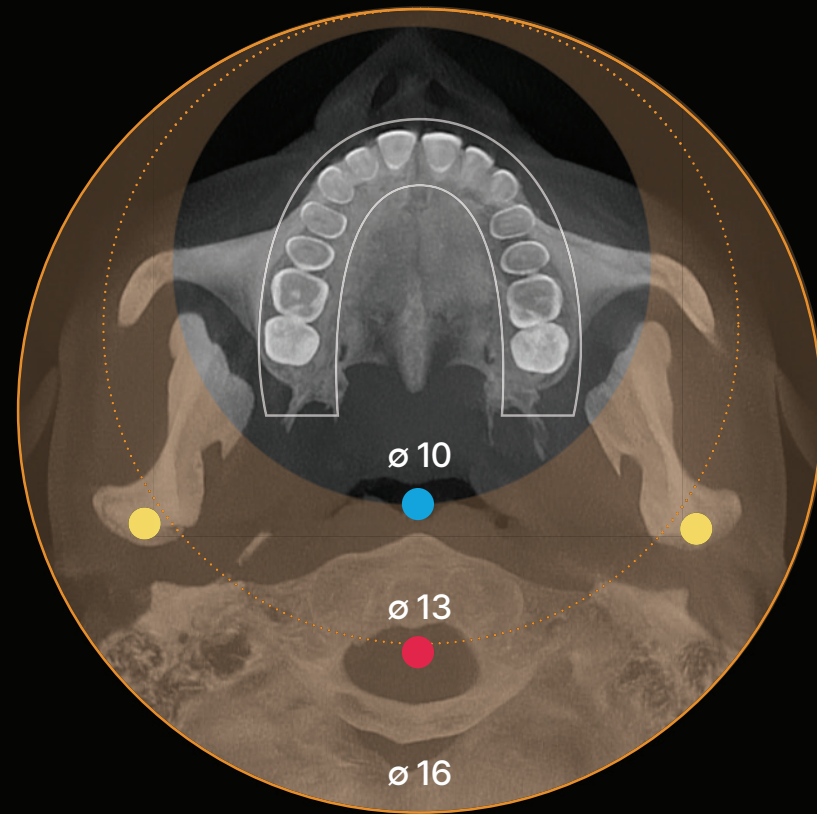

RAYSCAN α 3D area

RAYSCAN α+ 130 area

RAYSCAN α+ 160 area

Full dentition

Dual TMJ

Airway

Cervical spine

10 height

The FOV height is up to 10cm, which allows for a comprehensive examination of the inferior alveolar nerve, full dentition, maxillary sinus, sinus artery, and ostium in a single scan under the chin. This feature is highly beneficial for maxillary and mandibular implant treatment and is a practical surgical guide. In orthodontic treatment, this technology can examine deeply impacted teeth and supernumerary teeth.

For Implantology & Orthodontics

- Surgical planning and surgical guide fabrication
- Molar extraction • Treatment planning for impactions
- Airway and dual TMJ analysis

10 height

8 height

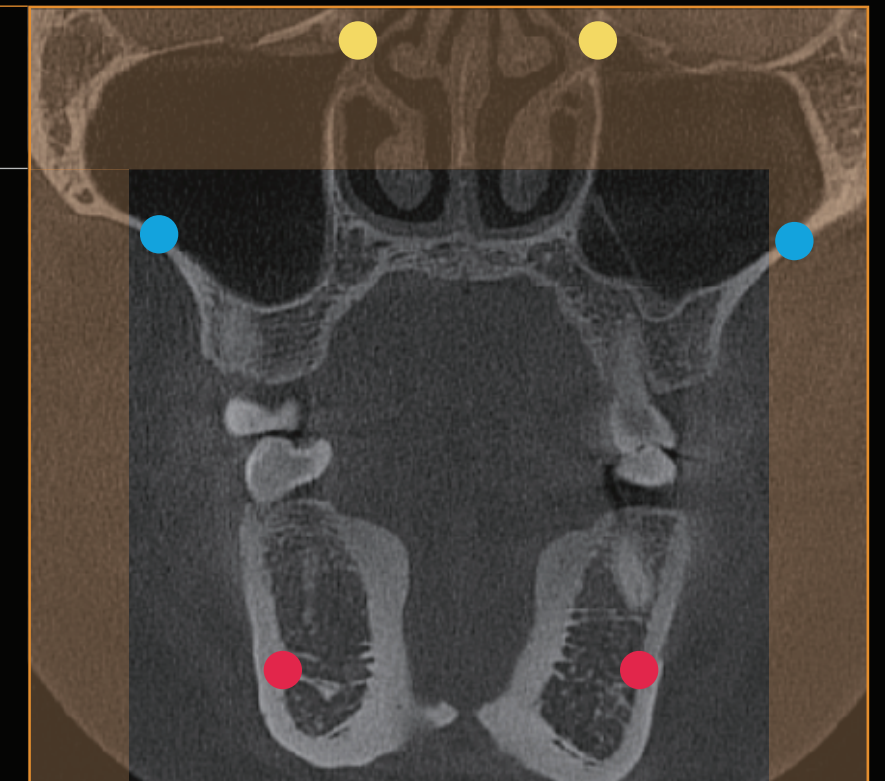

Competition

RAYSCAN α+ area

Ostium

Sinus artery

Mandibular nerve canal

Free-FOV Treatment Provides Diverse Treatment Possibilities

With RAYSCAN $\alpha+$, prioritizing patient well-being is paramount. We provide customizable scan volumes and high-resolution images to cater to individual clinical needs. Tailoring scan volumes ensures precise and diagnostic image acquisition, ensuring accurate diagnoses and targeted treatment planning.

Tackle More Dentistry

- Implantology • All-on-X implant planning • Orthodontics
- Complex impactions • Dual TMJ • Sinus and airway analyses
- Endodontics

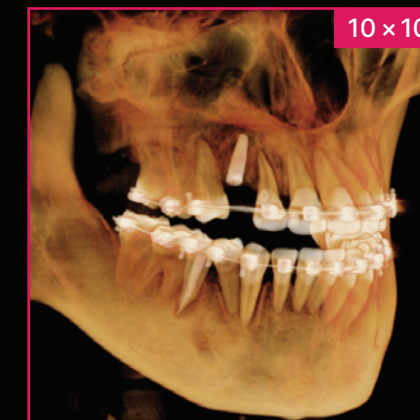
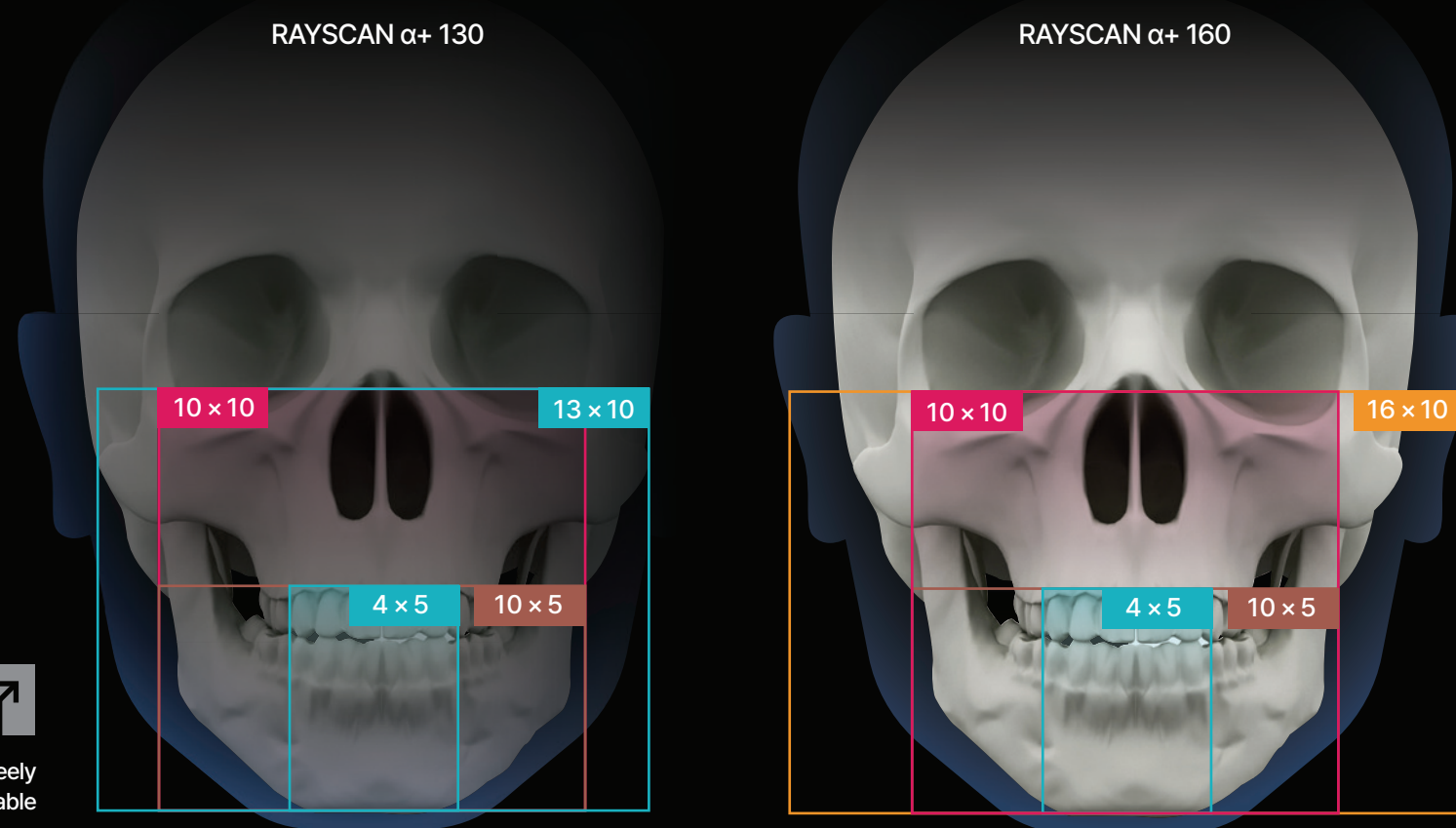

High-Resolution Imaging for Accurate Diagnosis

Experience exceptional image clarity and customizable scan volumes with RAYSCAN α+. Tailor your scans to meet your specific clinical needs, ensuring the capture of every intricate detail and unleash boundless possibilities.

Implant

FOV 10×10cm, 160μm

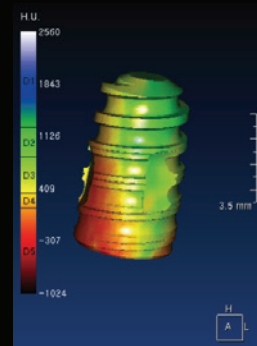
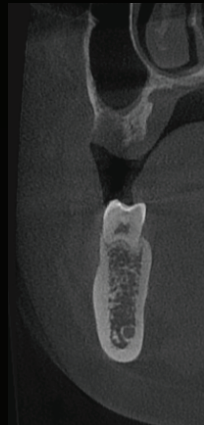
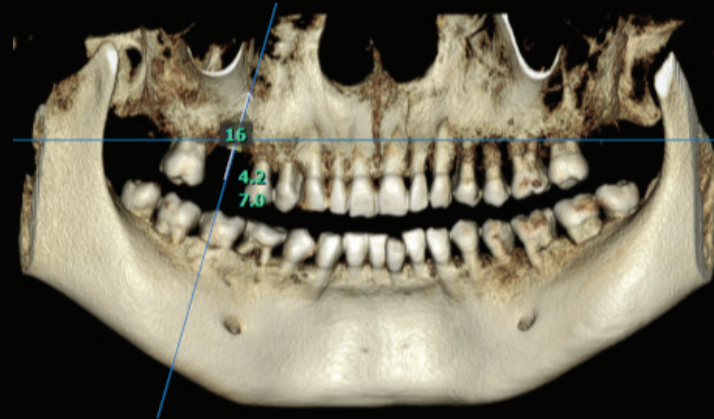

Orthodontic

FOV 16×10cm, 200μm

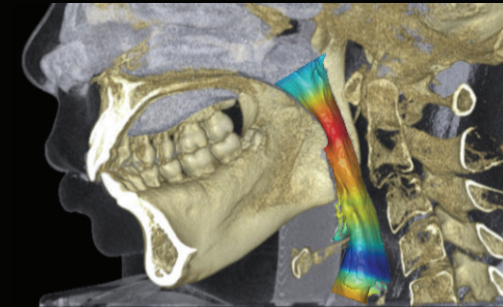
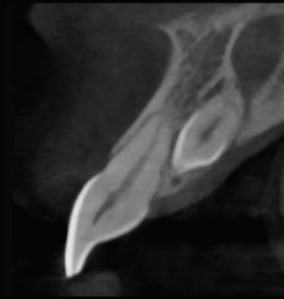

Endo

FOV 4×5cm, 70μm

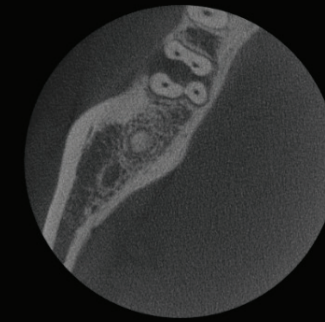
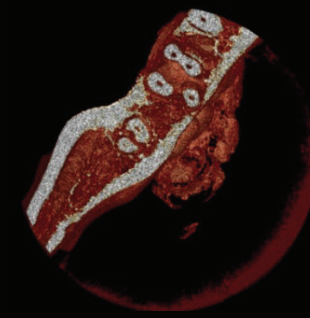

Diagnose all areas

FOV 4×5cm

FOV (cm)

Voxel size (mm)

70 μm

16×10

0.2

10×10

0.16

4×5

0.07

Rapid Reconstruction Time

RAYSCAN α+ allows for lightning-fast image reconstruction, empowering clinicians to review CT scans within a mere 8 seconds. This leads to reduced patient wait times and enhances the efficiency of treatment planning processes.

Significantly
Reduces Chair Time

8 sec
HD Scan
Reconstruction
Time

1 sec
Fast Scan
Reconstruction
Time



Wireless Remote for Maximum Convenience

Our remote control empowers patients and healthcare professionals with effortless operation, allowing them to focus on treatment outcomes.

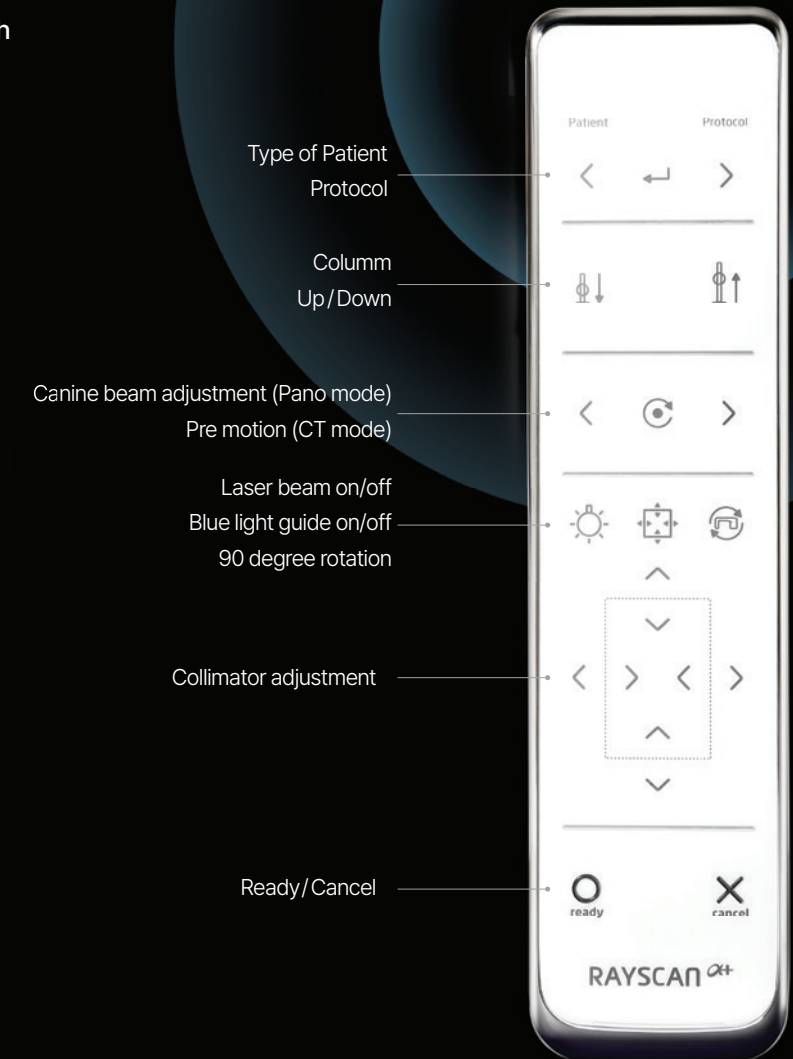

- Type of Patient Protocol
- Column Up/Down
- Canine beam adjustment (Pano mode)
- Pre motion (CT mode)
- Laser beam on/off
- Blue light guide on/off
- 90 degree rotation
- Collimator adjustment
- Ready/Cancel

RAYSCAN α+



FACE-DRIVEN DENTISTRY

RAYSCAN α+



Clear Panorama

- AMF (Adaptive Moving Focus) technology selects the optimal image layer to provide clear panoramic images, making it easy to identify the patient's periodontal condition and lesion location.



The state of the art technology for high-definition image quality

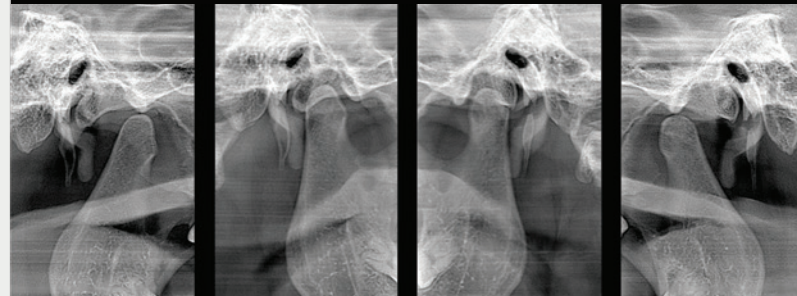
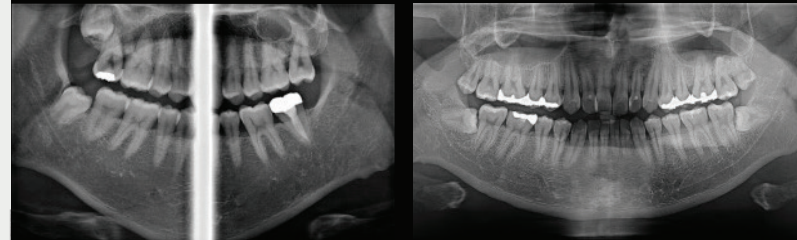

Optional Ceph Modality

- Option for direct conversion scan ceph or one-shot ceph sensors. One-shot ceph captures images in just 0.8 seconds, minimizing distortion and reducing patient radiation exposure. Direct conversion scan ceph attachment ensures hi-resolution ceph scans.

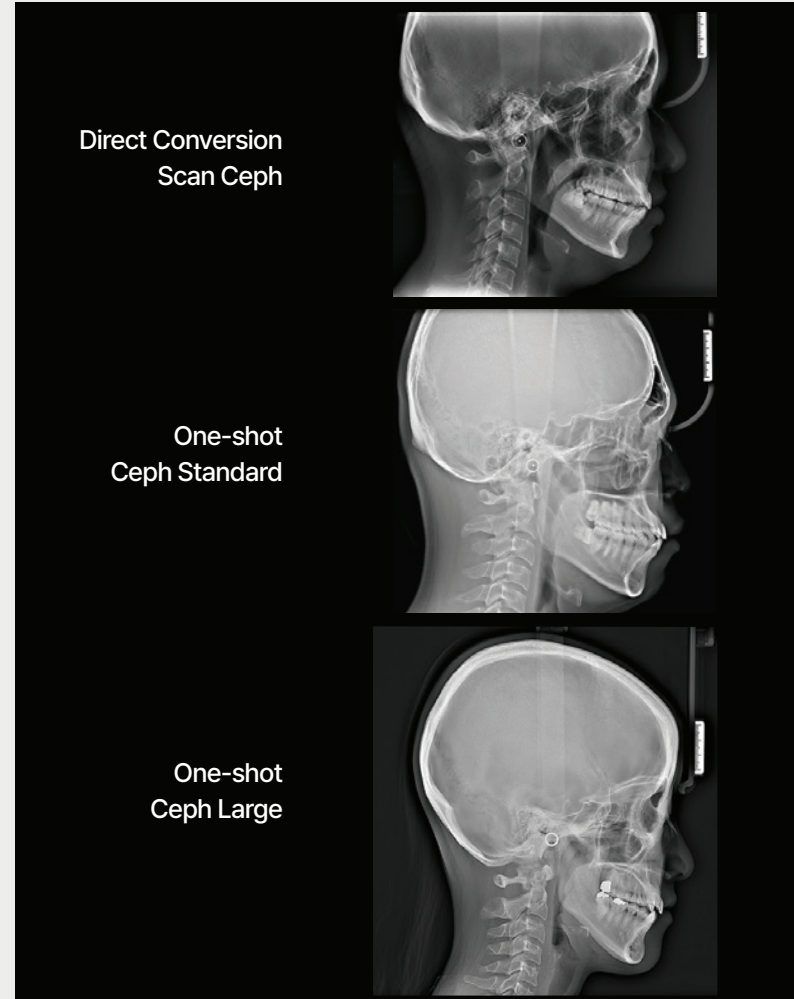

Impression Scan

- RAYSCAN α+ employs cutting-edge 3D scanning technology for its impression scanning feature, which captures data by imaging physical impressions and gypsum models. This gathered data can then be utilized to generate the STL file required for CAD/CAM applications.



Visible X-ray Guide

- The world's foremost visible X-ray guide prominently indicates the location of the scan area. Users can effortlessly capture the region of interest using a patient-safe visible blue-light guide method, ensuring convenience and safety.



'RAYGuard' is an Excellent Support System

24/7 monitoring system

- We monitor all of our installed X-ray units using an advanced IOT system called RAYGuard.
- RAYGuard's 24/7 monitoring support significantly reduces the time required to address detected issues. By proactively equipping the support team, it minimizes the need for multiple visits to resolve the same issue, enabling more efficient resolution.

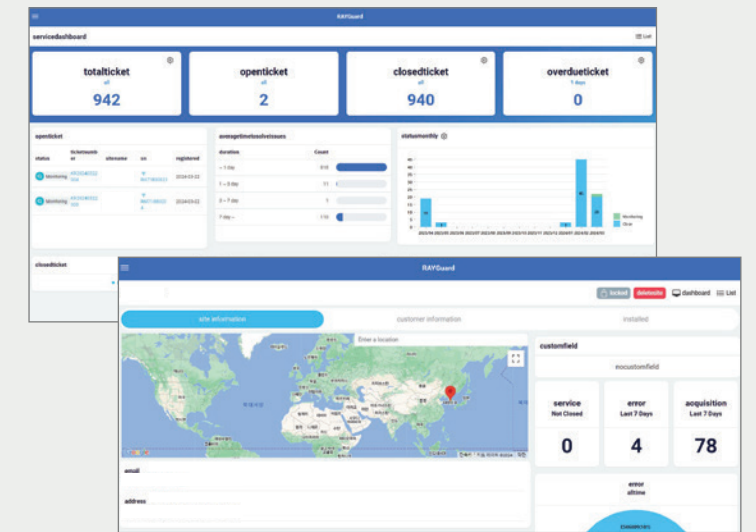

Software

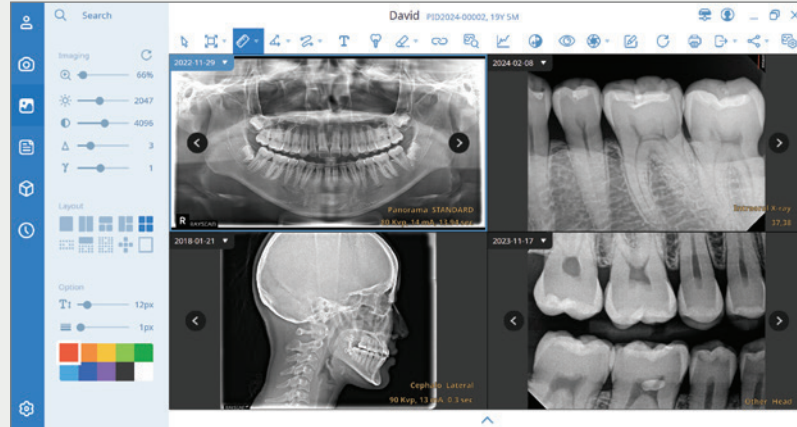

2D Imaging Software SMARTDent

- Integrated dental image management
- Implant & canal draw simulation
- Simple and powerful search(id, name, date, modality)
- 16 bits full imaging system with DICOM 3.0
- Supports TWAIN-compliant input devices
- Convenient layout



5D Imaging Solution 5D

- Accurate diagnosis & Analysis
- Powerful 5D rendering
- AI Technology
- Auto Nerve Tracking
- Auto Alignment & Segmentation
- Auto Arch Tracing
- Metal Artifact-Free
- DICOM print & CD/DVD burning

Specifications

Type	Cone Beam CT, Panoramic, Cephalometric, Object scan(CT Impression)	
Patient Positioning	Standing(Wheelchair accessible)	
Focal Spot	0.5mm	
Tube Current	1~17mA	
Tube Voltage	60~100kV	
CBCT	α+ 130	α+ 160
FOV Size	Max. 13×10(H) cm	Max. 16×10(H) cm
Free FOV support	Yes	
Scan Time	4.9~14sec	
Voxel Size	70~300μm	
Fast Scan Mode	Yes	
Object Scan Support	Yes(CT Impression & Model scan)	
Panoramic		
Free FOV Support	Yes	
Scan Time	Max.14sec	
Cephalometric (Option)		
Type & Scan Time	SC(Scan Ceph) Min. 4.0sec OCS(One-Shot Ceph Standard) Max. 0.8sec OCL(One-Shot Ceph Large) Max. 0.5sec	

Dimensions

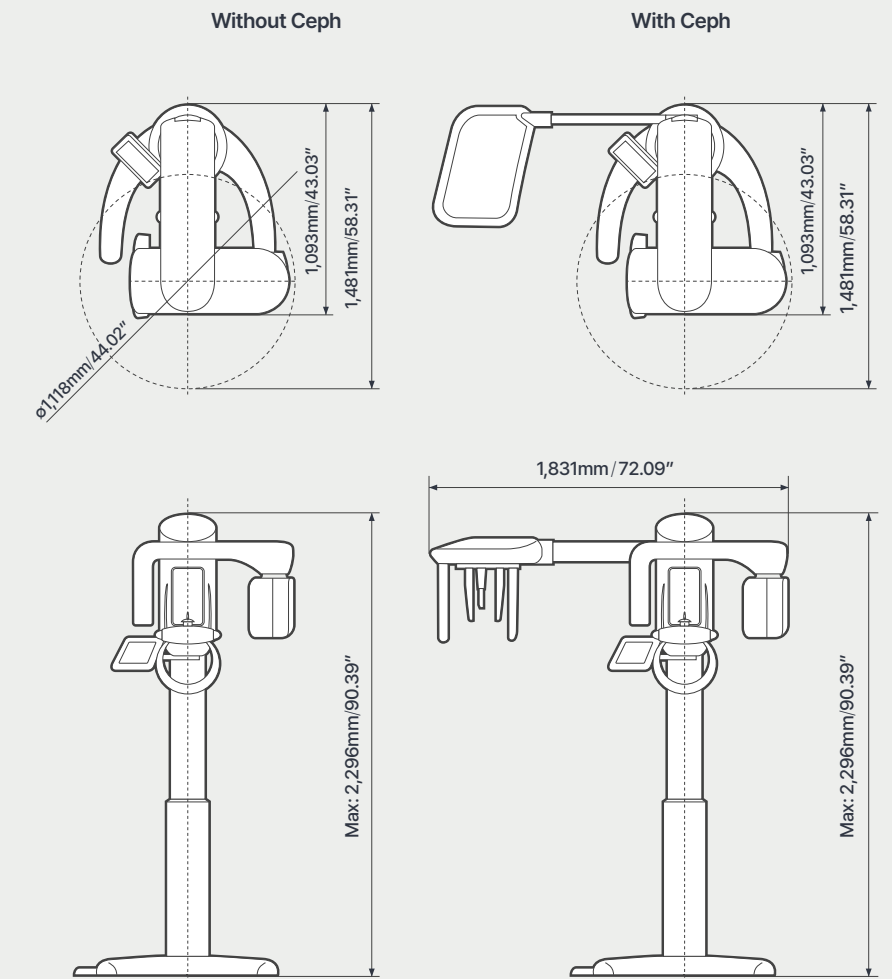

IDEA Bronze



REDDOT Winner



GD Best of Best



Ray

HQ. 12th Fl. 221, Pangyojeok-ro Seongnam-si, Gyeonggi-do, 13494, Republic of Korea
MFR 265, Daeji-ro, Suji-gu, Yongin-si, Gyeonggi-do, 16882, Republic of Korea
tel. +82. 031. 605. 1000 email ray_sales@raymedical.co.kr

EC REP Emergo Europe

Westervoortsedijk 60, 6827 AT Arnhem, The Netherlands

www.raymedical.com

D:O IMPLANT

Gurugram HO: 7061, 7062, 708, 709, 7101, 7102,
7111 & 7112, 7th Floor, Block B, Vipul Square,
Sushant Lok, Phase-I, Gurugram, Haryana - 122009

Team Marketing: 7303331511

E-mail: info@dioimplant.co.in

www.dioimplant.co.in